



Jetson AGX Orin Series

Thermal Design Guide

Document History

TDG-10943-001_v1.2

Version	Date	Description of Change
1.0	April 29, 2022	Initial release
1.1	July 19, 2022	<ul style="list-style-type: none">• Updated Table 2-1 “Jetson AGX Orin Series Thermal Specifications”• Updated Table 3-1 “Jetson AGX Orin Thermal”
1.2	April 28, 2023	<ul style="list-style-type: none">• Updated to include Jetson AGX Orin Industrial information throughout the document.• Updated Table 2-1: Jetson AGX Orin 32GB/64GB Thermal Specifications.• Added Table 2-2 Jetson AGX Orin Industrial Thermal Specifications with notes.• Added Table 3-2: Jetson Orin Industrial Thermal with notes.

Table of Contents

Chapter 1. Introduction	1
1.1 Customer Requirements	1
1.2 Related Documents.....	2
1.3 Definitions.....	2
1.3.1 Total Module Power	2
1.3.1.1 TMP Conditions	2
1.3.2 Thermal Transfer Plate	3
1.3.3 Orin SoC Temperature.....	4
Chapter 2. Specifications	5
2.1 Thermal Specifications	5
Chapter 3. Design Guidance	7
3.1 Thermal Information	7
3.1.1 Jetson AGX Orin Thermal Performance	7
3.1.2 Jetson AGX Orin Thermal Design Details	10
3.1.3 Customer Thermal Solution.....	12
3.1.4 Temperature Cycling	12
3.2 Mechanical Information	13
3.2.1 Assembly Guidelines.....	14
Chapter 4. Software Thermal Management	16
4.1 Temperature Monitoring.....	16
4.2 Fan Control.....	17
4.3 Orin SoC Recommended Operating Temperature Limit.....	18
4.4 Orin SoC Hardware Thermal Throttling.....	19
4.5 Orin SoC Thermal Trip Temperature	19

List of Figures

Figure 1-1.	Jetson AGX Orin – Topside ISO View	3
Figure 1-2.	Jetson AGX Orin – Backside ISO View	3
Figure 1-3.	Jetson AGX Orin Design – Exploded View	4
Figure 3-1.	Thermal Resistance Network	8
Figure 3-2.	Location of TTP Thermocouple	10
Figure 3-3.	Thermal Stack Up Schematic	11
Figure 3-4.	Jetson AGX Orin Top View	13
Figure 3-5.	Jetson AGX Orin Bottom View	13
Figure 3-6.	Jetson AGX Orin Side View	14
Figure 3-7.	Jetson AGX Orin System Assembly Example	14
Figure 3-8.	Mounting Screw Sequence	15
Figure 4-1.	Fan Control Behavior	17

List of Tables

Table 2-1.	Jetson AGX Orin 32GB/64GB Thermal Specifications	5
Table 2-2.	Jetson AGX Orin Industrial Thermal Specifications	6
Table 3-1.	Jetson AGX Orin 32GB/64GB Thermal	8
Table 3-2.	Jetson Orin Industrial Thermal	9
Table 4-1.	Jetson AGX Orin Default Fan	17

Chapter 1. Introduction

This document is the thermal design guide (TDG) for the NVIDIA® Jetson AGX Orin™ series modules.

The purpose of this thermal design guide is to provide the system-level thermal, mechanical and qualification requirements for the Jetson AGX Orin series modules.



Note: References to Jetson AGX Orin apply to either Jetson AGX Orin 32GB, Jetson AGX Orin 64GB and Jetson AGX Orin Industrial (JAOi) except where explicitly noted.

1.1 Customer Requirements

The customer requirements are as follows:

- ▶ Customers are responsible for reading and understanding this entire thermal design guide.
- ▶ Customers are responsible for implementing a thermal solution that maintains the NVIDIA Orin™ system on chip (SoC) and thermal transfer plate (TTP) temperatures below the specified temperatures in Table 2-1 under the maximum thermal load and system conditions for their use case.
- ▶ Customers are responsible for designing a system that delivers sufficient power to the Jetson AGX Orin to sustain the maximum thermal load for their use case.
- ▶ Customers are responsible for qualification of the Jetson AGX Orin in their system and are responsible for any issues related to failure to qualify the product properly.
- ▶ The TTP is not designed to be removed by the customer, as the thermal interface material (TIM) cannot be reused. The screws holding the TTP together are marked with tamper evident ink. Removal of the TTP is done solely at the customer's risk.

1.2 Related Documents

The following types of files are associated resources for Jetson AGX Orin.

- ▶ Jetson AGX Orin Module 3D CAD STEP Model
A 3D mechanical model of the board is available in the universal .stp file format. The model is provided to enable system level mechanical fit checks, mounting, and wiring planning.
- ▶ Jetson AGX Orin Series Module Data Sheet
The mechanical drawing of the Jetson AGX Orin module is included in the data sheet.

1.3 Definitions

This section describes terminology that will be referenced throughout this thermal design guide.

1.3.1 Total Module Power

The total module power (TMP) represents the average board power dissipation while the system is running the target workload under the worst-case conditions in steady state. System designs must be capable of providing sufficient cooling for the Jetson AGX Orin when operating at the TMP level.

1.3.1.1 TMP Conditions

TMP conditions for this design are defined under the following operating conditions:

- ▶ Worst-case Orin SoC temperature conditions
- ▶ Maximum power level for the product configuration
The TMP power level is based on the target workload
- ▶ Steady state average power

1.3.2 Thermal Transfer Plate

The Jetson AGX Orin is provided with a thermal transfer plate (TTP) to simplify integration with a system-level thermal solution. The Jetson AGX Orin is shown in Figure 1-1 (topside view) and Figure 1-2 (backside view).

Figure 1-1. Jetson AGX Orin – Topside ISO View

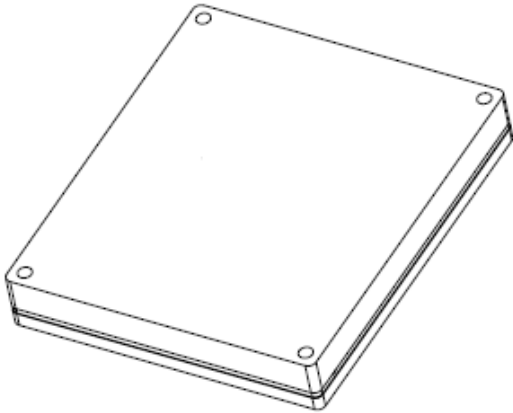
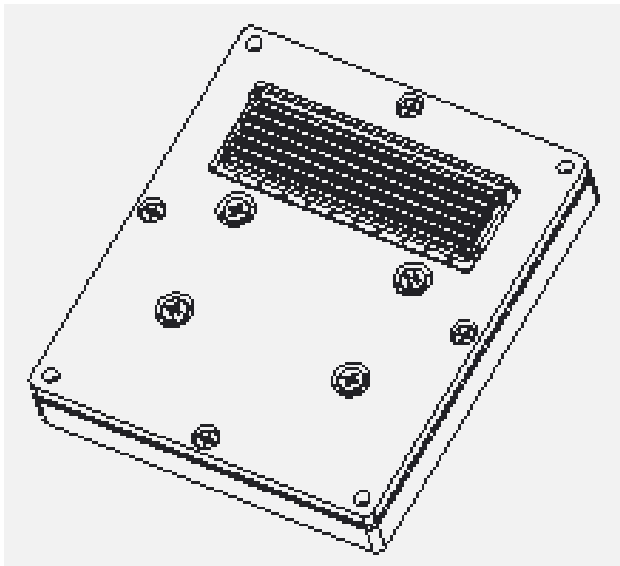

Figure 1-2. Jetson AGX Orin – Backside ISO View



The thermal solution of the customer's system design should attach to the top surface of the TTP. The thermal solution can be mounted using the main module mounting holes. More details are provided in Section 3.2.

An exploded view of the Jetson AGX Orin assembly is shown in Figure 1-3. The PCB is completely covered by the TTP. The TTP design mechanically isolates the Jetson AGX Orin board and components from external mechanical forces, standardizes the thermal and mechanical interface, and allows for modular system design.

Figure 1-3. Jetson AGX Orin Design – Exploded View

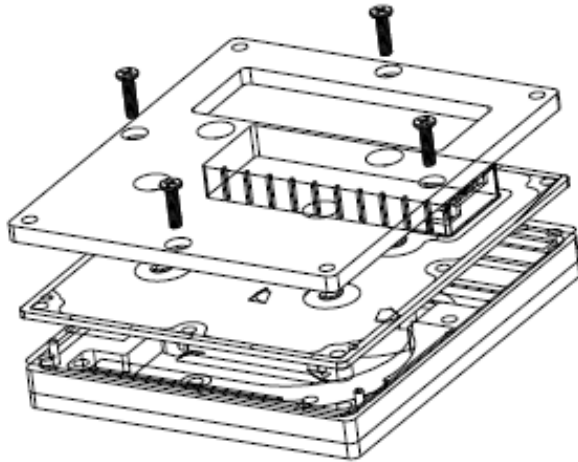

1.3.3 Orin SoC Temperature

The Orin SoC junction temperature (T_j) represents the Orin SoC die temperature read from the highest of the internal temperature sensors. The on-die thermal sensors are used for high-temperature T_j management and many other temperature-dependent functions. Details regarding the software thermal mechanisms are described in Chapter 4.

Chapter 2. Specifications

2.1 Thermal Specifications

This section provides thermal specifications separately for Jetson AGX Orin 32GB/Jetson AGX Orin 64GB, and Jetson AGX Orin Industrial (JAOi). On the Orin SoC there are multiple on-die temperature sensors that are placed close to dominant hotspots to measure temperature and engage thermal protection mechanisms. Chapter 4 contains the details related to these sensors and their thermal protection mechanisms. The specifications in Table 2-1 and Table 2-2 must be followed to maintain the performance and reliability of the Jetson AGX Orin module.

Table 2-1. Jetson AGX Orin 32GB/64GB Thermal Specifications

Parameter	Jetson AGX Orin 64GB		Jetson AGX Orin 32GB		Units
	50 W Mode	MaxN Mode ¹	40 W Mode	MaxN Mode ¹	
Maximum TTP operating temperature ²	80.0		80.0		°C
Recommended Orin SoC operating temperature limit ³	T.SoC = 99.0		T.SoC = 99.0		°C
Orin SoC maximum operating temperature ⁴	T.SoC = 105.0		T.SoC = 105.0		°C
Orin SoC shutdown temperature ⁴	T.SoC = 105.0		T.SoC = 105.0		°C

Notes:

¹The MaxN power mode allows for higher operating power levels and supports the 60 W module power. Different power modes use different thermal offset settings as configured in the software. These thermal offset settings are implemented by NVIDIA to meet product safety and reliability standards and should not be modified.

²The temperature of the TTP must always be kept within this 80 °C limit to maintain the specified performance and reliability. The measurement locations are provided in Figure 3-2.

³These are the temperature thresholds below which the product will operate at the specified clock speeds. Software will apply clock speed reductions once any of these temperature sensors exceed these the specified thresholds. Note that power fluctuations that induce T_j fluctuations above these thresholds will cause temporary clock reductions. See Section 4.3 for details.

⁴The Orin SoC will reset the Jetson AGX Orin module once any of these temperature limits are reached to maintain the safety of the Orin SoC. See Section 4.5 for details.

Table 2-2. Jetson AGX Orin Industrial Thermal Specifications

Parameter	Jetson AGX Orin Industrial		Units
	60W Mode	MaxN Mode ¹	
Maximum TTP operating temperature ²	85.0		°C
Recommended Orin SoC operating temperature ³	T.SoC = 105.0		°C
Orin SoC maximum operating temperature ⁴	T.SoC = 115.0		°C
Orin SoC shutdown temperature ⁵	T.SoC = 118.0		°C

Notes:

- ¹The MaxN power mode allows for higher operating power levels and supports the 75 W module power. Different power modes use different thermal offset settings as configured in the software. These thermal offset settings are implemented by NVIDIA to meet product safety and reliability standards and should not be modified.
- ²The temperature of the TTP must always be kept within this 85°C limit to maintain the specified performance and reliability. The measurement locations are provided in Figure 3-2.
- ³These is the temperature threshold below which the product will operate at the specified clock speeds.
- ⁴The reliability of the Jetson AGX Orin Industrial Module is set at the recommended Orin SoC Operating temperature limit, 115C, for 10000 hours and 77000 hours (10 Years) at 105C. Operating above the recommended Orin SoC operating temperature limit will negatively impact the reliability of the Orin SoC and is not recommended. See Section 4.3 for details.
- ⁵The Orin SoC will reset the Jetson AGX Orin Industrial module once this temperature limit is reached to maintain the safety of the Orin SoC. See Section 4.5 for details.

Chapter 3. Design Guidance

This chapter provides design guidance to meet the Jetson AGX Orin specifications.

3.1 Thermal Information

The design goal for system thermal management is to keep the TTP temperature and the Orin SoC temperature below the limits specified in Section 2.1. The TTP temperature limit maintains the component temperatures on Jetson AGX Orin within their temperature specifications.

Typical workloads that consume less than 60 W module power are likely to operate below the T_j temperature limits, so long as the TTP temperature is within the specification. For unbalanced workloads or higher power workloads, more analysis is needed to evaluate the thermal design. This is described in the following section.

3.1.1 Jetson AGX Orin Thermal Performance

The Jetson AGX Orin module is designed to have a system level thermal solution attached to the TTP to dissipate the TMP thermal load into the ambient environment. This can be represented with a thermal resistance network where thermal resistance is calculated based on the equation:

$$\theta_{12} = \frac{T_1 - T_2}{P}$$

Where:

θ_{12} The thermal resistance between Point 1 and Point 2

T_n The temperature at Point n

P The heat load (for example, dissipated power) transferred between Point 1 and Point 2

A simple example of a thermal resistance network is shown in Figure 3-1, where θ_{jp} represents the thermal resistance from T_j to the TTP and θ_{pa} represents the thermal resistance of the system thermal solution. The thermal resistance of the system thermal solution may include multiple components including, but not limited to, thermal interface material, heat spreaders, and heat sinks.

Figure 3-1. Thermal Resistance Network

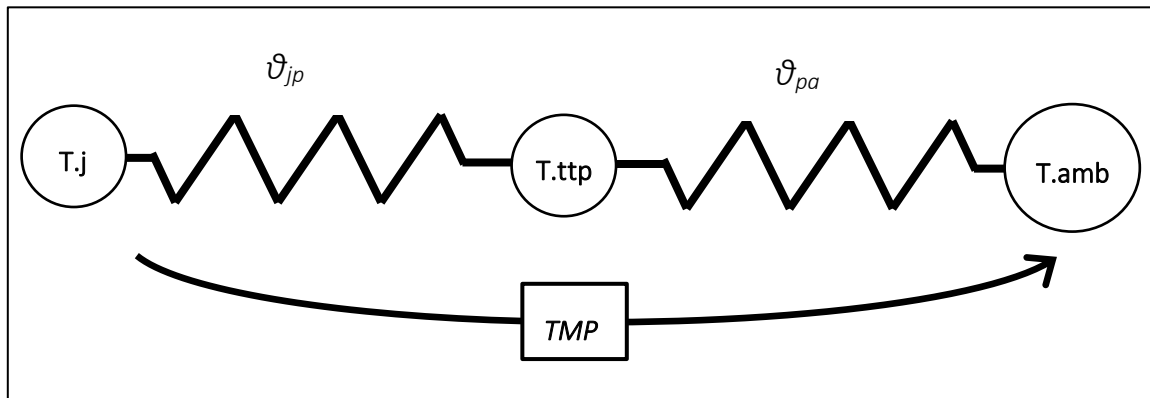

Jetson AGX Orin enables a wide variety of applications that may exercise different components on the module. The variation between applications will cause variation in heat loads on the different components on the Jetson AGX Orin and hotspots in different logical partitions of the Orin SoC. While Jetson AGX Orin is designed to spread the heat and make the thermal performance as consistent as possible, different applications have different levels of thermal performance. The more evenly the module power is distributed across the Jetson AGX Orin the better the thermal performance will be. Typical thermal performance of different workloads is listed in Table 3-1 and Table 3-2 separately for Jetson AGX Orin 32GB/Jetson AGX Orin 64GB and Jetson AGX Orin Industrial (JAOi).

Table 3-1. Jetson AGX Orin 32GB/64GB Thermal

θ	Jetson AGX Orin 64GB ¹		Jetson AGX Orin 32GB ¹		Units
	Balanced Workload ²	Unbalanced Workload ³	Balanced Workload ²	Unbalanced Workload ³	
θ_{jp}	0.36	0.77	0.42	1.12	°C/W
θ_{jb}^4	5.5				°C/W

Notes:

¹The Jetson AGX Orin 64GB values can be used to reference either the Jetson AGX Orin 64GB production module or the Jetson AGX Orin Developer Kit module with a max power of 60 W. In MAXN mode the module can be up to 60 W. Jetson AGX Orin 32GB module refers to the production module with a max power of 40 W.

²A balanced workload is well distributed across the CPU, GPU, DLA, PVA, and DRAM. This is expected to be representative of most use cases. The *Power Management for Jetson AGX Orin* document describes multiple power modes that widely distribute the power across the different partitions of the Orin SoC.

³In an unbalanced workload, the power is concentrated on a small area of the Orin SoC. This is not representative of most use cases. An example is a workload that is only running on the CPU partition. Preliminary values subject to change.

⁴The θ_{jb} value is provided for simulation of the Jetson AGX Orin module as a 2-resistor model in commercial CFD packages.

Table 3-2. Jetson Orin Industrial Thermal

θ	Jetson AGX Orin Industrial		Units
	Balanced Workload ¹	Unbalanced Workload ²	
θ_{jp}	TBD	TBD	°C/W
θ_{jb} ³	5.5		°C/W

Notes:

¹A balanced workload is well distributed across the CPU, GPU, DLA, PVA, and DRAM. This is expected to be representative of most use cases. The *Power Management for Jetson AGX Orin* document describes multiple power modes that widely distribute the power across the different partitions of the Orin SoC.

²In an unbalanced workload, the power is concentrated on a small area of the Orin SoC. This is not representative of most use cases. An example is a workload that is only running on the CPU partition. Preliminary values subject to change.

³The θ_{jb} value is provided for simulation of the Jetson AGX Orin Industrial module as a 2-resistor model in commercial CFD packages.

The thermal resistance of the module (θ_{jp}) and heat sink (θ_{pa}) sum together for the overall thermal resistance from the Orin SoC to ambient. The required heat sink thermal performance can be determined based on the ambient temperature conditions, use case, and TMP level required by the customer. Consider the following example:

$$T_{amb} = 50^{\circ}\text{C}$$

$T_{SoC} = 97^{\circ}\text{C}$ (Allowing headroom to account for T_j fluctuations resulting from power fluctuations)

$$\theta_{jp} = 0.36 \frac{^{\circ}\text{C}}{\text{W}} \text{ (Assuming a balanced workload)}$$

$$P_{TMP} = 50\text{W}$$

First, check the heat sink thermal performance requirement for the above conditions.

$$\theta_{ja} = \theta_{jp} + \theta_{pa} \rightarrow \theta_{pa} = \theta_{ja} - \theta_{jp} = \frac{97^{\circ}\text{C} - 50^{\circ}\text{C}}{50\text{W}} - \theta_{jp} = 0.94 \frac{^{\circ}\text{C}}{\text{W}} - 0.36 \frac{^{\circ}\text{C}}{\text{W}} = 0.58 \frac{^{\circ}\text{C}}{\text{W}}$$

So, the heat sink's thermal performance (θ_{pa}) must be better than 0.59 °C/W. Next, check that the TTP temperature will be below the 80 °C specification.

$$\theta_{pa} = \frac{T_p - T_a}{P} \rightarrow T_p = \theta_{pa} * P + T_a = 0.58 \frac{^{\circ}\text{C}}{\text{W}} * 50\text{W} + 50^{\circ}\text{C} = 79^{\circ}\text{C}$$

So, a 0.58 °C/W or better thermal solution will be sufficient to meet the T_j and TTP temperature specifications.

3.1.2 Jetson AGX Orin Thermal Design Details

The Jetson AGX Orin product is designed for integration with a product-level thermal solution which could be a passive heat sink, an active heat sink, a cold plate, a chassis mount, and so on. The thermal solution must attach to the top surface of the TTP.

The 75 × 73 mm area, as shown in Figure 3-2, is the key contact area for efficient cooling performance. Full contact with the entire top surface of the TTP is suggested for maximum cooling.

The TTP has a maximum operating temperature specified in Table 2-1. If the Jetson AGX Orin temperature is kept below this limit, then all other critical components on the PCB will be within their temperature limits as well. The TTP temperature is to be measured during qualification testing at the locations indicated by the two circles in Figure 3-2.

Figure 3-2. Location of TTP Thermocouple

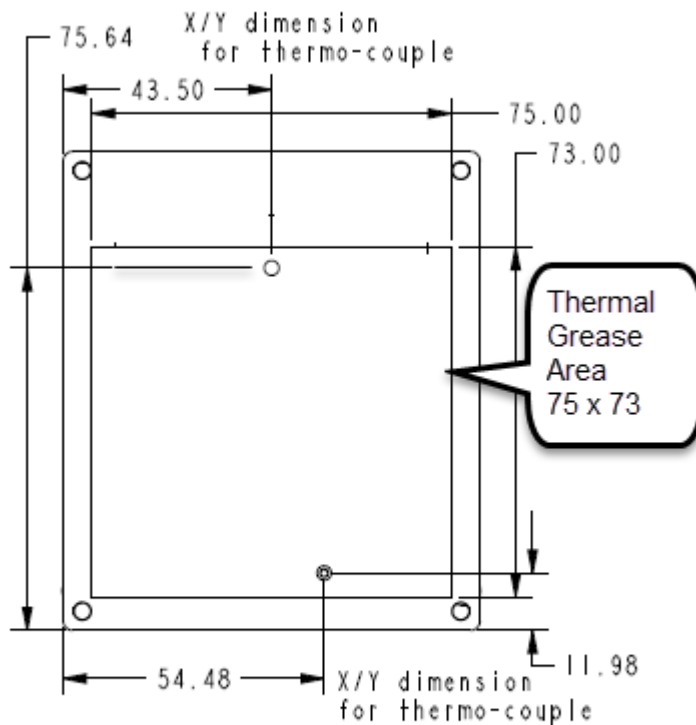

TIM Area for efficient cooling

In the Z-direction, the cold plate thermocouples should be located on the surface of the TTP as shown in Figure 3-2, indicated by Location 2 and Location 3. During thermal qualification, these are the only temperatures that need to be monitored with a thermocouple. The Orin SoC temperature (Location 1) is monitored by the software.

Note the following for Figure 3-3:

► Jetson AGX Orin Contents

Thermal transfer plate and backside stiffener. The thermal transfer plate has an internal heat spreader plate connected to the Orin SoC to reduce the thermal performance variation between workloads.

PCB with components.

TIM. Henkel TGF3600. TIM is applied on all components necessary to maintain the component temperatures within their specified limits.

► Customer Requirements (The customer is responsible for the following items)

HS_TIM. The customer is responsible for providing the thermal interface material between the TTP and the thermal solution. For best thermal performance, the TIM should provide low thermal impedance within the mechanical, reliability, and cost constraints of the customer's product.

Thermal Solution. A thermal solution capable of cooling the appropriate amount of TMP for the target workload.

Maximum TTP Temperature. To ensure that the maximum Orin SoC operating temperature is less than the value specified in Table 2-1 (shown as Location 1 in Figure 3-3), and the maximum TTP temperature must not exceed the value specified in Table 2-1 (shown as Location 2 in Figure 3-3).

Figure 3-3. Thermal Stack Up Schematic

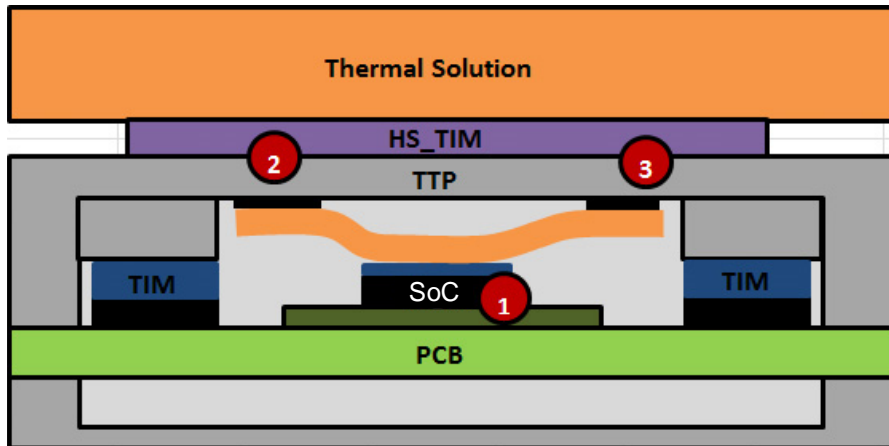

3.1.3 Customer Thermal Solution

The customer's thermal solution is the mechanical element that interfaces to the NVIDIA TTP and provides cooling. The thermal solution must attach to the top surface of the TTP, but a variety of configurations are possible depending on the customer's chassis design. In all cases however, the following recommendations are applicable:

- ▶ Good contact of the thermal solution to the TTP is critical for maximizing the thermal performance of the Jetson AGX Orin. The Orin SoC is located directly under the TTP and consumes the majority of the TMP. Thus, using a TIM that provides good thermal contact between the thermal solution and the TTP is crucial.
- ▶ NVIDIA thermal testing has demonstrated that if the TTP temperature does not exceed the maximum specified temperature, then the rest of the components will be within their specified operating temperature range.
- ▶ The customer thermal solution should include adequate margin to account for module-to-module variations.

3.1.4 Temperature Cycling

Long-term reliability of all solder interconnects is negatively impacted by temperature cycling. It is the customer's responsibility to minimize the component's exposure to temperature cycling and to not exceed that which the component is qualified. NVIDIA's graphics and core logic components are qualified to JEDEC standard JESD47.



Note: NVIDIA recommends that customers refer to JESD94.01 (*Application Specific Qualification Using Knowledge Based Test Methodology*) for more information.

3.2 Mechanical Information

Jetson AGX Orin partners should refer to the CAD model provided in Section 1.2 for the exact product dimensions to determine how to interface the TTP with their thermal solution and ensure mechanical compatibility in their system. The top view, bottom view, and side views are shown in Figure 3-4, Figure 3-5, and Figure 3-6, respectively.

Figure 3-4. Jetson AGX Orin Top View

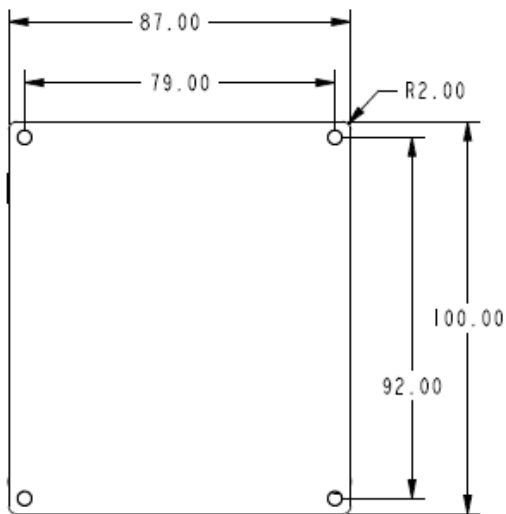

Figure 3-5. Jetson AGX Orin Bottom View

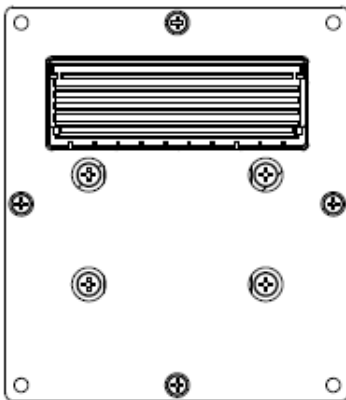
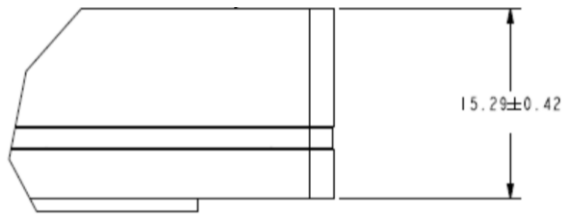

Figure 3-6. Jetson AGX Orin Side View



3.2.1 Assembly Guidelines

The Jetson AGX Orin and TTP are provided as a complete unit. Orientation of the unit is to be aligned with the board-to-board connector and secured to the baseboard as shown in Figure 3-7. Care should be taken to make sure that the mounting screws are not inserted at an angle and that they go through the thermal solution, the TTP, and the backside stiffener. The mounting screws must thread into standoffs that contact the backside stiffener to support the module. Note that the connector alone cannot be used to support the module.

Figure 3-7. Jetson AGX Orin System Assembly Example

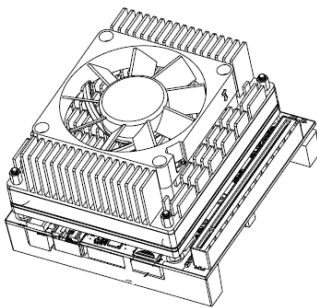

The following are suggested assembly guidelines:

1. Install the Jetson AGX Orin by the carefully aligning the module connector with the base board connector.
2. Insert the module connector into the base board connector.
3. Install each mounting M3 screw into the heat sink.
 - a). If the TIM has been pre-applied to the heat sink, make sure to remove the protective cap covering the TIM.
 - b). If the TIM was not pre-applied to the heat sink, apply the TIM to the center of the module as shown in Figure 3-2.
4. Align the heat sink with the module.

- Each mounting M3 screw should be attached loosely in the sequence shown in Figure 3-8. The tightening sequence should be followed for two cycles. On the last tightening sequence, the screws should be fully torqued.

Figure 3-8. Mounting Screw Sequence

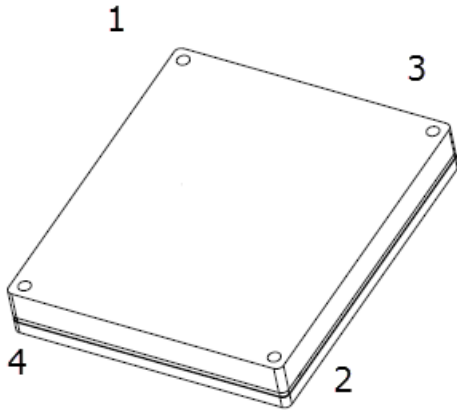

Chapter 4. Software Thermal Management

4.1 Temperature Monitoring

The Jetson Power GUI is a graphical user interface tool for monitoring the power and thermal status of Jetson platforms. The tool reports various power and thermal related information which would help the user to understand power and thermal behavior of Jetson platforms.

To run Jetson Power GUI follow these two steps:

1. Click the nvpmode GUI represented by an NVIDIA icon on the right side the Ubuntu desktop's top bar.
2. Click the "Run Jetson Power GUI" submenu item.

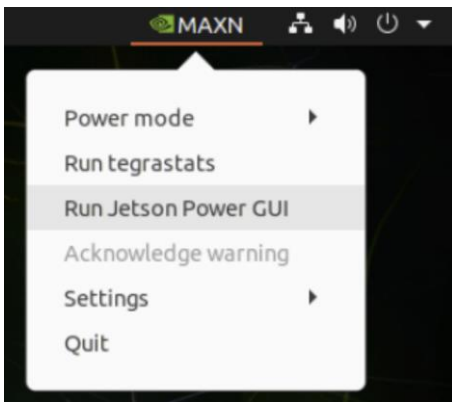

4.2 Fan Control

The Jetson AGX Orin can be configured to control a system fan. Pulse width modulation (PWM) output and tachometer input are supported. Jetson AGX Orin has configurable fan control of step-based speed control with hysteresis¹, example as shown in Figure 4-1.

Figure 4-1. Fan Control Behavior

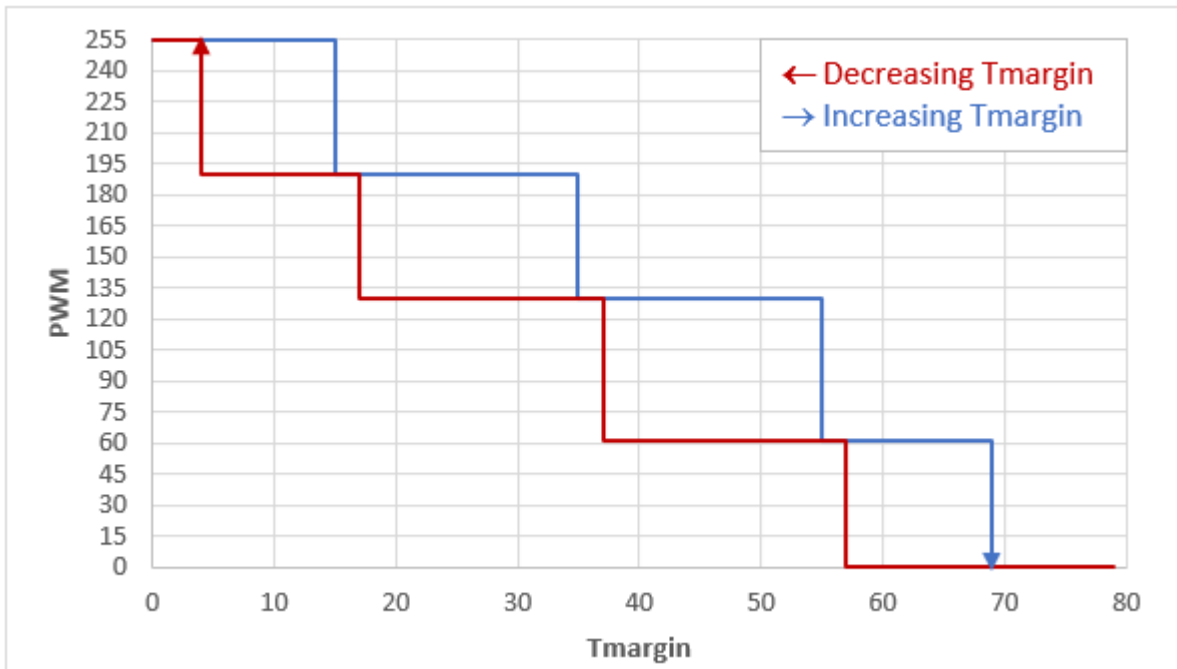

The default fan table is listed in Table 4-1. Note that PWM is configured on a 2^8 scale, with 255 being equivalent to 100% duty cycle.

Table 4-1. Jetson AGX Orin Default Fan

Tmargin ²	PWM	Hysteresis (°C)
57	62	12
37	130	20
17	190	20
4	255	13

Notes:

¹Fan control architecture is subject to change with next software GA release.

²TMARGIN temperature is the difference between the GROUP_MAX_TEMP and the current thermal zone temperature, where GROUP_MAX_TEMP = 105 °C.

4.3 Orin SoC Recommended Operating Temperature Limit

The recommended operating temperature limit is the threshold at which the module will operate without performance reduction. These temperatures are listed in Table 2-1 and Table 2-2 and cannot be adjusted. The customer's tolerance for performance reduction should determine the amount of T_j operating headroom in the thermal solution design to accommodate the temperature sensor uncertainty of ± 3 °C.

Software thermal management operates as follows:

- ▶ When the measured temperature is at or below the operating temperature threshold, software T_j thermal management is not engaged. The system is free to vary the system frequencies and voltages by the DVFS algorithm.
- ▶ When the measured temperature reaches the thermal management threshold, the internal thermal sensors generate an interrupt to software. At this point the software thermal management algorithm engages and begins periodically performing the following operations:

 Polling temperature.

 Running a thermal management control algorithm to calculate the throttle degree, indicating the amount of throttling to apply during the next time period.

 Throttle the system to the level of throttling indicated by the throttling control algorithm.

 Throttling is applied through limits on the clock frequency of high-power units such as the CPU and GPU. Higher throttling degree results in lower frequency limits. DVFS policies operate within these frequency limits.

- ▶ Software thermal management remains in operation until the Orin SoC temperature has returned to a value below the throttling threshold and throttling degree has returned to zero.



Note: Power fluctuations that induce T_j fluctuations above the software thermal management thresholds will cause temporary clock reductions. Power fluctuations in the target workload should be evaluated for their potential to cause temperature to fluctuate above the software threshold.

4.4 Orin SoC Hardware Thermal Throttling

If the software thermal management is not able to maintain the Orin SoC temperature, then the hardware thermal throttling will engage in an attempt to prevent an over-temperature thermal trip. Thermal trips on Jetson AGX Orin cause the system to reset. To avoid thermal trip conditions without being overly conservative, Orin SoC has hardware-engaged clock throttling mechanisms that are used as a last resort to prevent thermal trip conditions. This will lower the Orin SoC temperature, but it will also significantly reduce the overall Orin SoC performance. The Orin SoC throttle settings cannot be altered. These settings are implemented by NVIDIA to meet product safety and reliability standards.

4.5 Orin SoC Thermal Trip Temperature

The Orin SoC is rated to operate at a junction temperature not-to-exceed 105 °C. Jetson AGX Orin has hardware thermal trip mechanisms that enforce this limit by automatically performing a system reset when this temperature is exceeded.

The thermal trip temperature should not be reached at any time during normal operation, but it may occur if cooling system components are broken, jammed, or otherwise unable to cool the Orin SoC under worst-case conditions. If a thermal trip event is triggered, then a major fault in the Jetson AGX Orin or system cooling solution has occurred. Thermal trip can be initiated by any of the sensors listed in Table 2-1. Using multiple sensors enables operation closer to the temperature limit without compromising reliability by reducing the uncertainty associated with the hotspot location.

The following thermal trip mechanisms have been Implemented:

- ▶ Internal sensor-based thermal trip. Failsafe thermal trip is guaranteed by using the thermal trip signal directly from the SoC to the PMIC. After the failsafe thermal trip, the system will reset without the user pressing the power button or equivalent input.
- ▶ T.diode and temperature-monitor-based thermal trip. When the external temperature monitor detects that the T.diode temperature is above a pre-programmed thermal trip, the monitor's THERM output signals the PMIC to reset the system without any software control. This is a back-up mechanism to the internal sensor-based thermal trip, so it is intentionally margined to a higher temperature to avoid contention with internal sensor-based thermal trip.

The Orin SoC thermal trip settings cannot be altered. These settings are implemented by NVIDIA to meet product safety and reliability standards.

Notice

This document is provided for information purposes only and shall not be regarded as a warranty of a certain functionality, condition, or quality of a product. NVIDIA Corporation ("NVIDIA") makes no representations or warranties, expressed or implied, as to the accuracy or completeness of the information contained in this document and assumes no responsibility for any errors contained herein. NVIDIA shall have no liability for the consequences or use of such information or for any infringement of patents or other rights of third parties that may result from its use. This document is not a commitment to develop, release, or deliver any Material (defined below), code, or functionality.

NVIDIA reserves the right to make corrections, modifications, enhancements, improvements, and any other changes to this document, at any time without notice.

Customer should obtain the latest relevant information before placing orders and should verify that such information is current and complete.

NVIDIA products are sold subject to the NVIDIA standard terms and conditions of sale supplied at the time of order acknowledgement, unless otherwise agreed in an individual sales agreement signed by authorized representatives of NVIDIA and customer ("Terms of Sale"). NVIDIA hereby expressly objects to applying any customer general terms and conditions with regards to the purchase of the NVIDIA product referenced in this document. No contractual obligations are formed either directly or indirectly by this document.

Unless specifically agreed to in writing by NVIDIA, NVIDIA products are not designed, authorized, or warranted to be suitable for use in medical, military, aircraft, space, or life support equipment, nor in applications where failure or malfunction of the NVIDIA product can reasonably be expected to result in personal injury, death, or property or environmental damage. NVIDIA accepts no liability for inclusion and/or use of NVIDIA products in such equipment or applications and therefore such inclusion and/or use is at customer's own risk.

NVIDIA makes no representation or warranty that products based on this document will be suitable for any specified use. Testing of all parameters of each product is not necessarily performed by NVIDIA. It is customer's sole responsibility to evaluate and determine the applicability of any information contained in this document, ensure the product is suitable and fit for the application planned by customer, and perform the necessary testing for the application in order to avoid a default of the application or the product. Weaknesses in customer's product designs may affect the quality and reliability of the NVIDIA product and may result in additional or different conditions and/or requirements beyond those contained in this document. NVIDIA accepts no liability related to any default, damage, costs, or problem which may be based on or attributable to: (i) the use of the NVIDIA product in any manner that is contrary to this document or (ii) customer product designs.

No license, either expressed or implied, is granted under any NVIDIA patent right, copyright, or other NVIDIA intellectual property right under this document. Information published by NVIDIA regarding third-party products or services does not constitute a license from NVIDIA to use such products or services or a warranty or endorsement thereof. Use of such information may require a license from a third party under the patents or other intellectual property rights of the third party, or a license from NVIDIA under the patents or other intellectual property rights of NVIDIA.

Reproduction of information in this document is permissible only if approved in advance by NVIDIA in writing, reproduced without alteration and in full compliance with all applicable export laws and regulations, and accompanied by all associated conditions, limitations, and notices.

THIS DOCUMENT AND ALL NVIDIA DESIGN SPECIFICATIONS, REFERENCE BOARDS, FILES, DRAWINGS, DIAGNOSTICS, LISTS, AND OTHER DOCUMENTS (TOGETHER AND SEPARATELY, "MATERIALS") ARE BEING PROVIDED "AS IS." NVIDIA MAKES NO WARRANTIES, EXPRESSED, IMPLIED, STATUTORY, OR OTHERWISE WITH RESPECT TO THE MATERIALS, AND EXPRESSLY DISCLAIMS ALL IMPLIED WARRANTIES OF NONINFRINGEMENT, MERCHANTABILITY, AND FITNESS FOR A PARTICULAR PURPOSE. TO THE EXTENT NOT PROHIBITED BY LAW, IN NO EVENT WILL NVIDIA BE LIABLE FOR ANY DAMAGES, INCLUDING WITHOUT LIMITATION ANY DIRECT, INDIRECT, SPECIAL, INCIDENTAL, PUNITIVE, OR CONSEQUENTIAL DAMAGES, HOWEVER CAUSED AND REGARDLESS OF THE THEORY OF LIABILITY, ARISING OUT OF ANY USE OF THIS DOCUMENT, EVEN IF NVIDIA HAS BEEN ADVISED OF THE POSSIBILITY OF SUCH DAMAGES. Notwithstanding any damages that customer might incur for any reason whatsoever, NVIDIA's aggregate and cumulative liability towards customer for the products described herein shall be limited in accordance with the Terms of Sale for the product.

Trademarks

NVIDIA, the NVIDIA logo, Jetson AGX Orin, and NVIDIA Orin are trademarks and/or registered trademarks of NVIDIA Corporation in the U.S. and other countries. Other company and product names may be trademarks of the respective companies with which they are associated.

Copyright

© 2022, 2023 NVIDIA Corporation. All rights reserved.